

Profile Data O-Ring OR

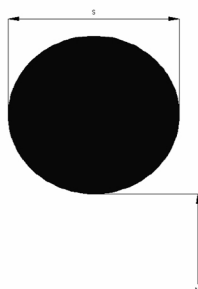

General

O-Rings are used in widely differing technical areas, for instance as individual sealing elements in pneumatics and hydraulics, and as preload elements for seals and wipers. O-Rings are double acting, activated by the system pressure. The sealing effect is generated by axial or radial preload. The preload of the O-ring is superposed by the hydraulic pressure, thus assuring the overall sealing pressure.

Features

- ⇒ Sealing over a wide range of pressures, temperatures and tolerances.
- ⇒ Simple and compact design.
- ⇒ Symmetrical profile cross section.
- ⇒ Wide application ranges.
- ⇒ Simple mounting.
- ⇒ Compact and simple grooves.
- ⇒ Easy and cost saving constructions possible.

Application

Static sealing (e.g. flanges and threaded joints), rotation and linear movement applications with minor loads and small groove dimensions, preload element for PTFE seals and wipers.

Installation

Snap-in installation

Installation

Snap-in installation

Seal housing recommendation

Tolerances	[mm]	
s	f7/H8	
Surface roughness	Rtmax [μ]	Ra [μ]
Bottom of groove	≤ 6.3	≤ 1.6
Face of groove	≤ 15	≤ 3
Sliding surface	Rtmax [μ]	Ra [μ]
	≤ 6.3	≤ 1.6

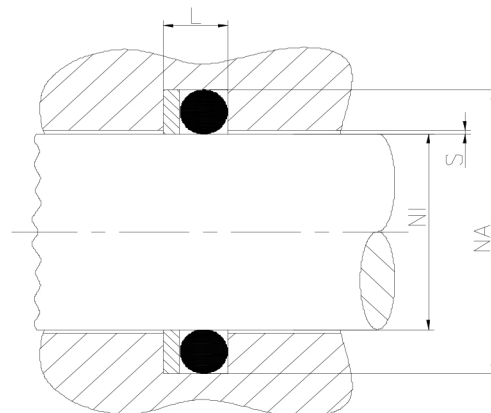

Sealco House, Maypole Fields Halesowen, West Midlands, UK, B63 2QB

T: (+44)1384 413058 E: sales@sealco.co.uk W: www.sealco.co.uk