

Profile Data

Symmetrical Seal PRS19C

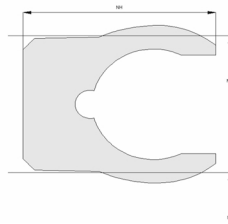

Function

Symmetrical piston/rod seals are designed to seal the pressurized hydraulic fluid against the atmosphere or between two pressurized spaces.

Features

- ⇒ Symmetrical, single acting piston/rod seal.
- ⇒ Preload effected through Helicoil-spring which ensures high pressure on the rounded sealing lips..
- ⇒ Excellent static and dynamic sealing performance.
- ⇒ Excellent sealing performance in low and high pressure ranges.
- ⇒ Useable for short and long stroke lengths.
- ⇒ Low friction in dry running or poor lubrication conditions.
- ⇒ Also used for gas applications.
- ⇒ Negligible tendency to “stick-slip” effect, small break away loads.

Application

Reciprocating and swivelling pistons in hydraulic cylinders, plungers.
 Chemical and pharmaceutical industry, aggressive fluids and high temp.
 Max. pressure 160 bar, max. speed 5 m/s linear; 0,1m/s rotating.

Installation

Installation in open housing, snap-in installation possible in special designed housings.

We recommend to maintain a nominal width/seal height ration (CS/NH) above 1/1,5.

Seal housing recommendation

Tolerances	[mm]	
L < 10mm	+ 0.2	
L ≥ 10mm	+ 0.3	
∅ NA (rod groove)	H10	
∅ NI (rod diam.)	f8	
∅ NA (cylinder diam.)	H9	
∅ NI (piston groove)	h10	
Surface roughness	Rtmax [μ]	Ra [μ]
Bottom of groove	≤ 6.3	≤ 1.6
Face of groove	≤ 15	≤ 3
Sliding surface	Rtmax [μ]	Ra [μ]
PU, elastomeres	≤ 2.5	≤ 0.1-0.5
PTFE	≤ 2	≤ 0.05-0.3

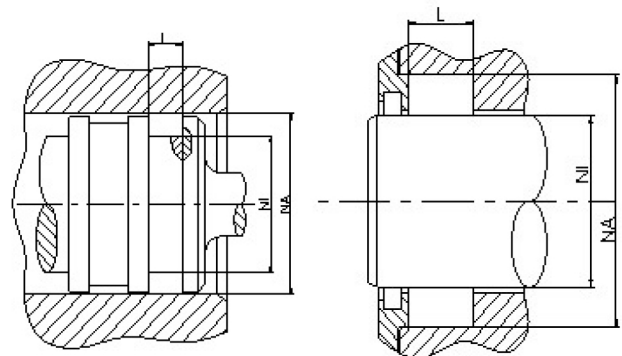

Sealco House, Maypole Fields Halesowen, West Midlands, UK, B63 2QB

T: (+44)1384 413058 E: sales@sealco.co.uk W: www.sealco.co.uk