

# Profile Data

## Piston Seal PS09A

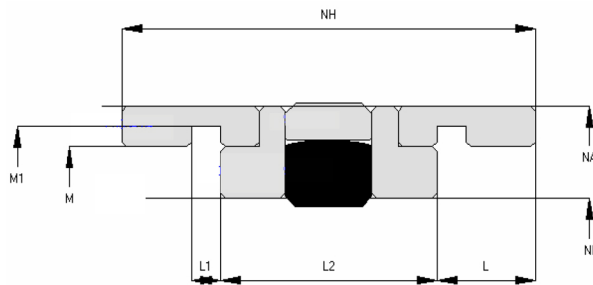

### **Function**

Compact piston seal set, designed to seal the hydraulic fluid between two pressurized spaces, preventing the flow of the fluid to the other side and transforming the pressure force into the movement.

### **Features**

- ⇒ Double acting piston seal, designed with interference on the ID which provides a good static fit in the groove.
- ⇒ Consisting of one gliding, energizing, two back-up and two guide elements.
- ⇒ Useable for short and long stroke lengths.
- ⇒ Compact piston design possible
- ⇒ Good static and dynamic sealing performance.
- ⇒ Good positioning control.

### **Application**

Reciprocating pistons in hydraulic cylinders.  
 Universal piston seal for double-acting cylinders.  
 Max. pressure 400 bar, max. speed 0.5 m/s.

### **Installation**

Snap-in installation.  
 The deformation of the energizing element during installation should not exceed 30% - risk of permanent deformation!

### **Seal housing recommendation**

|                          |                  |               |
|--------------------------|------------------|---------------|
| <b>Tolerances</b>        | <b>[mm]</b>      |               |
| NL                       | + 0.2            |               |
| NH                       | + 0.2            |               |
| ∅ NA                     | H9               |               |
| ∅ NI                     | h10              |               |
|                          |                  |               |
| <b>Surface roughness</b> | <b>Rtmax [μ]</b> | <b>Ra [μ]</b> |
| Bottom of groove         | ≤ 6.3            | ≤ 1.6         |
| Face of groove           | ≤ 15             | ≤ 3           |
|                          |                  |               |
| <b>Sliding surface</b>   | <b>Rtmax [μ]</b> | <b>Ra [μ]</b> |
| PU, elastomer            | ≤ 2.5            | ≤ 0.1-0.5     |
| PTFE                     | ≤ 2              | ≤ 0.05-0.3    |

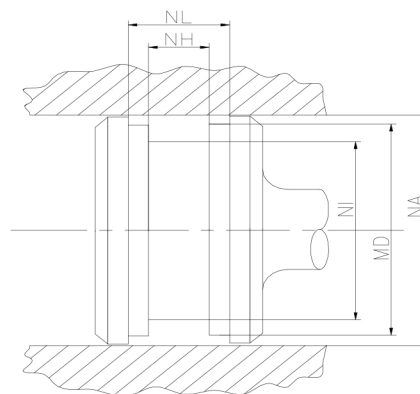

Sealco House, Maypole Fields Halesowen, West Midlands, UK, B63 2QB

T: (+44)1384 413058 E: sales@sealco.co.uk W: www.sealco.co.uk