

Profile Data Rod Seal RS17A

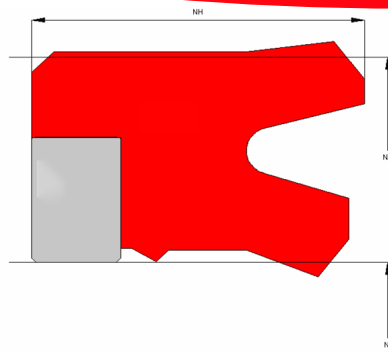

Function

Rod seals are designed to seal the pressurized hydraulic fluid against the atmosphere, preventing leakage and pollution of the environment.

Features

- ⇒ Asymmetrical, single acting rod seal, designed with interference on the OD which provides a good static fit in the groove.
- ⇒ Dynamic sealing lip shorter than static lip to avoid drag pressure.
- ⇒ Secondary lip for stabilising at large seal heights and reducing the residual oil film.
- ⇒ Activated back-up ring prevents and reduces gap extrusion.
- ⇒ Excellent static and dynamic sealing performance.
- ⇒ Useable for long stroke lengths.
- ⇒ Negligible tendency to “stick-slip” effect above a speed of 0.15 m/s.

Application

Reciprocation rods in hydraulic cylinders, plungers.
Mainly used in telescopic cylinders.
Max. pressure 700 bar, max. speed 0.5 m/s.

Installation

Snap-in installation.

Seal housing recommendation

Tolerances	[mm]	
L < 10mm	+ 0.2	
L ≥ 10mm	+ 0.3	
∅ NA	H10	
∅ NI	f 8	
Surface roughness	Rtmax [μ]	Ra [μ]
Bottom of groove	≤ 6.3	≤ 1.6
Face of groove	≤ 15	≤ 3
Sliding surface	Rtmax [μ]	Ra [μ]
PU, elastomer	≤ 2.5	≤ 0.1-0.5
PTFE	≤ 2	≤ 0.05-0.3

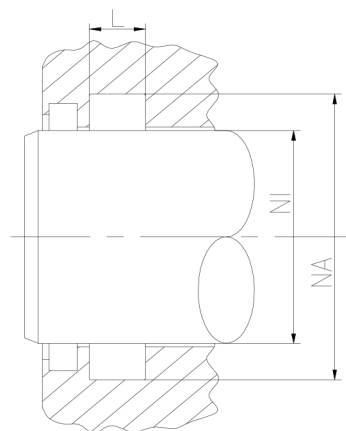

Sealco House, Maypole Fields Halesowen, West Midlands, UK, B63 2QB

T: (+44)1384 413058 E: sales@sealco.co.uk W: www.sealco.co.uk