

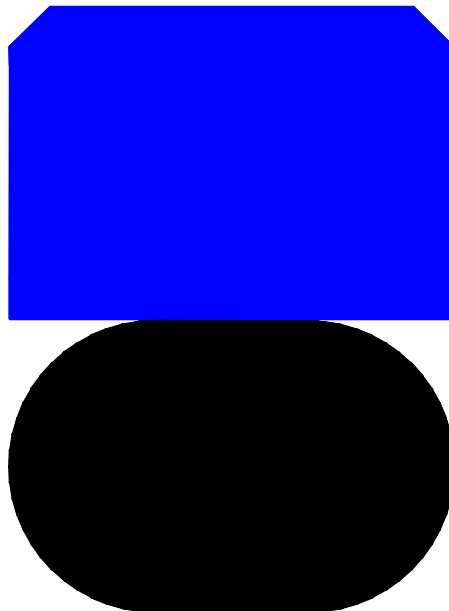

O.L. Seals A/S

Piston Seals

Kefloy SlipRing® Type 2522-



Double acting piston seal for reciprocating movements.

Offers excellent wear resistance and low friction.



SlipRing® Type 2522-

Is a double acting piston seal consisting of an outer sliding part of Kefloy® energized by a rubber O-Ring. SlipRing® is pressure responsive. SlipRing® can be used with a great variety of fluids. Kefloy® is compatible with virtually all fluids. To avoid extrusion and ease installation SlipRing® type 2522- is chamfered.

SlipRing® type 2522- is available in Standard series, Light Duty series and Heavy Duty series.



Working Range

Pressure

Up to 80 MPa. For pressures exceeding 40 MPa, please contact your O.L. Seals distributor.

Temperature

-50°C to + 200°C. For temperatures exceeding this temperature range, please contact your O.L. Seals distributor.

Velocity

Reciprocating up to 15 m/sec. Frequency: Up to 5 HZ. Should not be used for rotating or oscillating applications.

Fluids

Kefloy® is compatible with virtually all fluids – liquids as well as gases. By selecting the right compound for the O-Ring energizer, it is possible to cover almost all fluids.

Advantages

- Good wear resistance
- Low friction
- No stick-slip

- Simple groove design
- Available for all diameters up to 2.500 mm
- Compatible with virtually all fluids

Material Selection Guide

Fluid	Mating surface	SlipRing® compound
Hydraulic oil	Steel	Kefloy® 13
Motor oil	Steel, hardened	Kefloy® 32
Grease	Chrome plated steel	
Other mineral oils	Cast iron	
Water	Aluminium	Kefloy® 22
Water hydraulic	Stainless steel	Kefloy® 90
Steam	Bronze	
Non lubricating fluids	Soft metals	
Air, dry or lubricated	Steel	Kefloy® 22
	Steel, hardened	Kefloy® 28
	Chrome plated steel	Kefloy® 90
	Cast iron	
	Aluminium	
	Stainless steel	
	Bronze	
	Soft metals	

Fluid	O-Ring compound
Hydraulic oil	
Motor oil	NBR (Buna N)
Grease	
Other mineral oils	At temperatures above 120°C use Viton O-Rings
Water, cold	
Water hydraulic	
Air, dry or lubricated	
Water, hot	EPDM
Steam	
Synthetic hydraulic fluids	Special compounds

O-Ring manufacturer's recommendation for the actual fluid should always be followed.

For other fluids or sealing surfaces, please consult your O.L. Seals distributor.



Seal Selection Guide

Standard Series

For most double acting applications the Standard Series is the best choice.

Can be used for single acting applications where the fluid is a gas.

Light Duty Series

Where very low friction is required, the Light Duty Series is recommended.

Ordering Example

Piston diameter: 253.7 mm

Part no 25224-2537-13
 SlipRing® Type Series
 Piston dia. x 10
 Compound no
 O-Ring size 227.97 x 7.00
 O-Ring to be ordered separately

Where space limitations make it necessary the light Duty Series should be chosen.

Heavy Duty Series

Where a very long service life is required the Heavy Duty Series should be chosen.

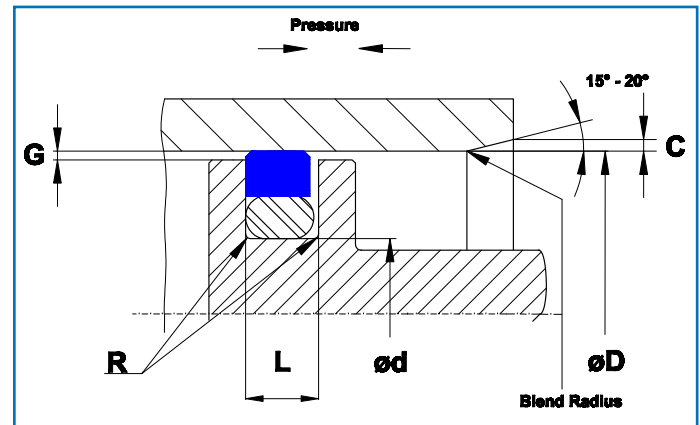

Installation dimensions

Notches

In systems with rapid pressure changes, e.g. power steering systems, it is necessary to furnish the SlipRings® with sidewall notches. The notches ensure a quick seal response to pressure changes.

To order SlipRing® with notches – add suffix “N” behind the compound code.

Example: 25223-1175-13N

Type No.	Standard Series Piston dia.	Light Series Piston dia.	Heavy Series Piston dia.	d Groove diam.	L Groove width	R Ra- dius	G Radial gap			C Cham- fer	B O-ring ID	O-ring Cross section
	H9	H9	H9	h9	+0.2 -0	Max.	10MPa (100 bar)	20MPa (200 bar)	40MPa (400 bar)	Min.		
25220	8-14.9	15-39.9	-	D-4.9	2.2	0.4	0.30	0.20	0.15	0.7	ød	1.78
25221	15-39.9	40-79.9	8-14.9	D-7.5	3.2	0.6	0.40	0.25	0.15	1.0	ød	2.62
25222	40-79.9	80-132.9	15-39.9	D-11.0	4.2	1.0	0.40	0.25	0.20	1.3	ød	3.53
25223	80-132.9	133-329.9	40-79.9	D-15.5	6.3	1.3	0.50	0.30	0.20	2.0	ød	5.33
25224	133-329.9	330-669.9	80-132.9	D-21.0	8.1	1.8	0.60	0.35	0.25	2.5	ød	6.99
25225	330-669.9	670-999.9	133-329.9	D-24.5	8.1	1.8	0.60	0.35	0.25	3.0	ød	6.99
25226	670-999.9	≥1000	330-669.9	D-28.0	9.5	2.5	0.70	0.50	0.60	3.5	ød	8.40
25227	≥1000		670-999.9	D-38.0	13.8	3.0	1.00	0.70	0.60	4.0	ød	12.00

O-Ring Size

O-Ring cross section according to installation dimensions.

O-Ring I.D. as close to groove dia. d as possible.

O-Ring I.D. not bigger than groove dia. d +3%

O-Ring I.D. not smaller than groove dia. d -5%

Important Note

The limits of pressure, temperature and velocity are individual maximum values. Heat generated by the friction may cause local increase of temperature. The cooling possibilities for the system determines the combinations of maximum values.