



# SEALCO

PERFORMANCE SEALING SOLUTIONS



## **THE COMPANY**

The Company .....	3
The Products .....	3
Typical Applications .....	3

## **INTRODUCTION**

Quality, Expertise and Flexibility .....	4
How does a High Tech Metal Seal work ...	5
Terminology .....	5

## **SEAL TYPES**

C-Seals .....	6
O-Seals .....	7

## **HOW TO ORDER**

The part number system .....	8
------------------------------	---

## **SEAL DATA SHEETS**

OI-Seals .....	12
OE-Seals .....	13
CI-Seals .....	14
CE-Seals .....	15
CSI-Seals .....	16
CSE-Seals .....	17
CA-Seals .....	18
WI-Seals .....	20
WE-Seals .....	21
Shaped Seals & specials .....	22
Tolerances .....	23
Conversion table .....	24

## **OTHER SEALCO PRODUCTS**

PTFE-seals .....	25
O Rings and Cord .....	26
Back-up Rings .....	26
Rotary Shaft Seals .....	26
Shaft Repair Kits .....	26
Front seals .....	27
Gland / Piston Seals .....	27
Wiper / Scraper Seals .....	27



## THE COMPANY

Sealco was established in 1990, to provide impartial technical support for the most demanding of applications.

We offer over 5 decades of experience and technical support; our customers can be confident that they will receive the most suitable sealing solution, manufactured onsite or sourced from our global suppliers to the highest standards.

## THE PRODUCTS

In conjunction with our partners HTMS, which stands for High Tech Metal Seals, Sealco provides a high sealing level under the most extreme working conditions whether the medium is gas or liquid. Our metallic O- and C-rings are manufactured in high performance nickel alloys and stainless steels.

The sealing concept is based on the elastic deformation of the seal during the compression cycle, which gives a contact point on each sealing surface. The different base material characteristics and the different temper modes determine the compressive load of the seal. This load, combined with an accurate compression rate, results in a specific pressure, which is directly related to the sealing level obtained (self-energization).

Metal seals use the hydrostatic pressure forces to obtain the highest sealing level possible (pressure energization). A wide variety of springs offers better self energization (spring energization). These three types of energization (self-, spring- and pressure energization) create sufficient pressure necessary to make the seal flow into the flange imperfections. A directly bounded plating or coating creates a soft, ductile outer surface layer and provides the highest sealing possible.



Internal C Rings with DSO from 6,48

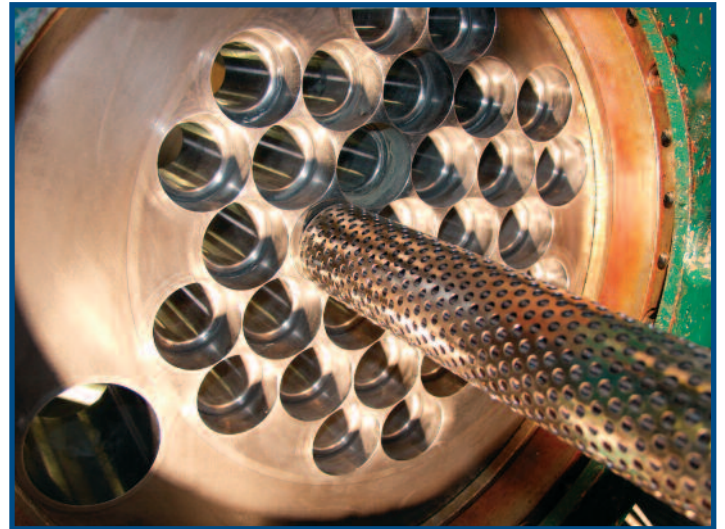

Polyester filters

Metal sealing products are generally used in static applications and are capable to seal under the most extreme conditions.

## TYPICAL APPLICATIONS

- Vacuum and ultra-high vacuum
- Plastic mouldings
- Accelerators
- Research laboratories
- Reactors and nuclear installations
- Diesel and other engines
- Aerospace
- Oil and petrochemical industries
- Hydraulics
- Valves, pumps, compressors
- Turbines
- Boilers and heat exchangers
- Chemical industries
- Iron and steel industries
- All applications where the use of elastomer seals are restricted by temperature, corrosion, radiation, pressure, gas permeability and life requirements.

# INTRODUCTION

## QUALITY

- Computer controlled welding equipment with individual weld printouts on request.
- 100% LP test on O-seal welds.
- X-rays on request.
- 100% visual inspection of plating and coating layers.
- ISO-9001 certified, qualification and audits by individual customers.
- Helium leak test.
- Load and Springback test.
- Heat treatment.
- High quality products.

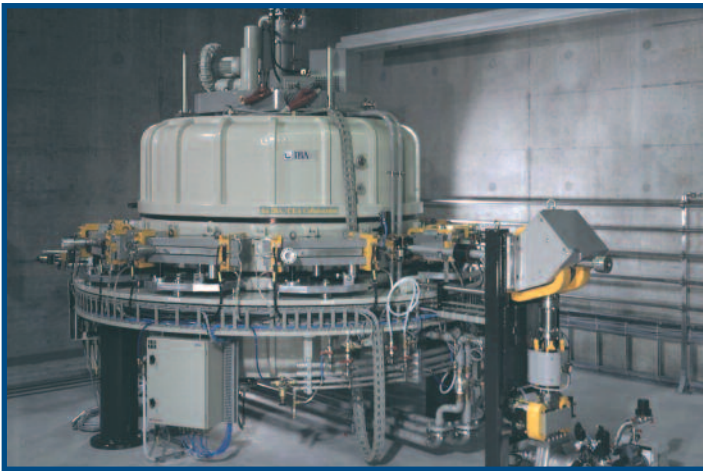

*Electron beam accelerator*

## EXPERTISE

- Know-how: Specialists with more than 25 years of experience.
- In house testing: Mechanical properties, new materials and production methods.
- Customer support : Thinking with customer.
- R&D: U-rings, E-rings, Custom designed seals, innovation.
- Direct contact with technical staff.

*We can do research on new materials and make new seal types or adapt our standard types of seals in order to meet the customers needs.*



*Quality control X-rays*

## FLEXIBILITY

- Very short delivery terms, special rush delivery service within one or two weeks
- Seals in any size (starting from 5mm), in any required quantity.
- Products according to the customers' requirements.
- Very short response time on customers demands (standard 1 day).
- Competitive pricing.
- Wide range of standard materials.

*Seals in any size*



*Leak detection and test equipment*

# HOW DOES A METAL SEAL WORK ?

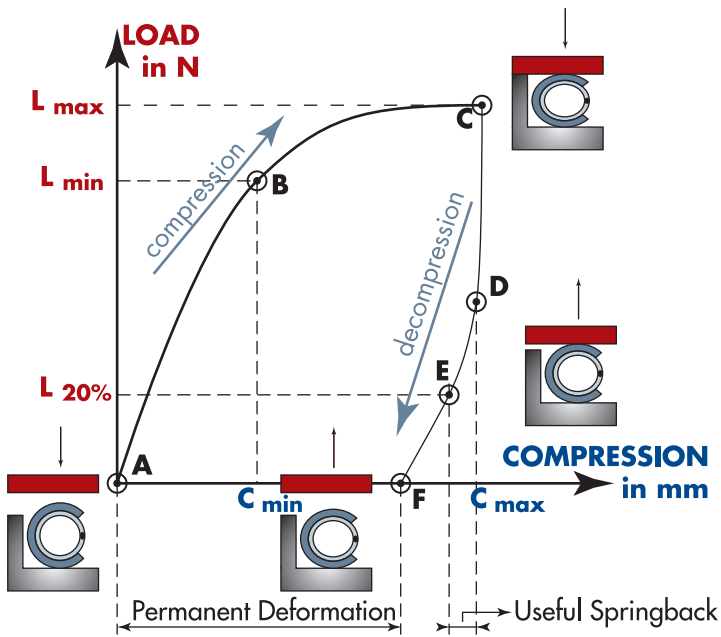

## COMPRESSION CYCLE (A – C), INSTALLATION OF THE SEAL.

- A** Seal before compression
- B** Seal at minimum compression ( $C_{min}$ ) = maximum groove depth
- C** Seal at maximum compression ( $C_{max}$ ) = minimum groove depth  
Between these two points (B and C) optimum sealing is obtained. Minimum and maximum groove depth for any given seal can be found in the data sheets further in this catalogue.

## DECOMPRESSION CYCLE (C – F), RELEASING THE BOLD LOAD.

- D** At this point the seals' resilience overcomes the remaining (decompression) load, this resilience is called springback.
- E** Springback of the seal at 20% of the maximum load ( $L_{max}$ ) is the useful springback.
- F** Springback of the seal at zero load is total springback = elastic recovery of the seal.

The different types of metal seals have different load-compression characteristics. Individual load compression diagrams can be obtained up on request.

## TERMINOLOGY

### Pressure energization

Meaning that the hydrostatic pressures are used to benefit the self-energization of the seal .  
Especially at high pressures (above 21Mpa) this becomes a "sealing-advantage" and enables High Tech Metal Seals to seal at 170Mpa and above.

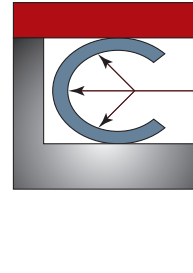

*In the case of a metal C-ring the hydrostatic pressure will create a counter force in the cavity of the C.*

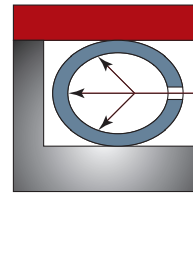

*In the case of a metal O-ring, hydrostatic pressure will be let in by means of drilled holes. (vented O-ring)*

## SEALCO OFFERS A VARIETY OF SEALS WITH OTHER TYPES OF ENERGIZATION

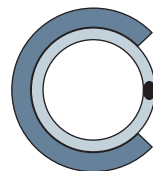

Spring energised  
C-ring

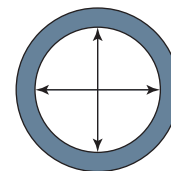

Gas filled  
O-ring

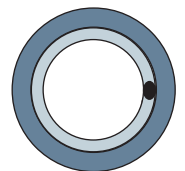

Spring energised  
O-ring

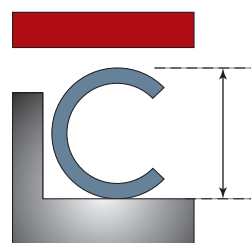

### Axial Section (mm)

Also known as free height.  
This is the height of the High Tech Metal Seal before installation.  
This measure is always without plating- or coating-layer thickness.

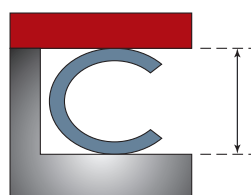

### Working section (mm)

This is the height of the seal when installed and is equivalent to the groove depth .  
Many of our seals can over bridge large groove depth-tolerances due to sufficient compression ranges .



# C-RING STANDARD PROFILES

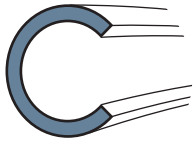

CI

## METAL C-RING INTERNAL PRESSURE FACE SEAL

### Features:

- Moderate Load ( lighter flanges and fewer bolts )
- Good springback
- High pressure capability

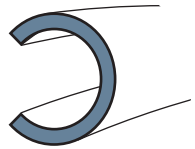

CE

## METAL C-RING EXTERNAL PRESSURE FACE SEAL

### Features:

- Moderate Load
- Good springback
- High pressure capability

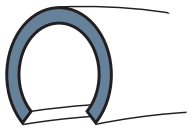

CA

## METAL C-RING, AXIAL SEAL

### Features:

- Close tolerance seal
- For light installation loads

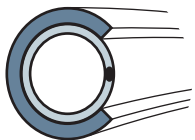

CSI

## SPRING ENERGISED METAL C-RING INTERNAL PRESSURE FACE SEAL

### Features:

- Lowest leak rate
- High pressure capability
- High load

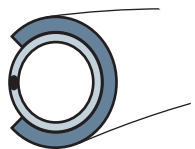

CSE

## SPRING ENERGISED METAL C-RING EXTERNAL PRESSURE FACE SEAL

### Features:

- Lowest leak rate
- High pressure capability
- High load

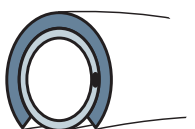

CSA

## SPRING ENERGISED METAL C-RING, AXIAL SEAL

### Features:

- Capable of sealing higher reversing pressure than standard CA seal

# O-RING STANDARD PROFILES

## METAL O-RING INTERNAL PRESSURE FACE SEAL

### Features:

- Avoids ingress of the working fluid into the seal
- Moderate load
- Moderate pressure capability

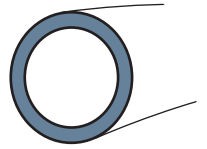

## METAL O-RING INTERNALLY VENTED AND PRESSURE-ENERGISED FACE SEAL

### Features:

- Moderate Load
- High pressure capability

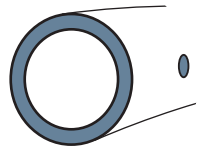

## METAL O-RING EXTERNALLY VENTED AND PRESSURE-ENERGISED FACE SEAL

### Features:

- Moderate Load
- High pressure capability

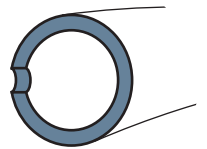

## METAL O-RING EXTERNALLY/INTERNALLY SPRING-ENERGISED FACE SEAL AND AXIAL SEAL

### Features:

- High Load
- Lowest leak rate
- Moderate pressure capability

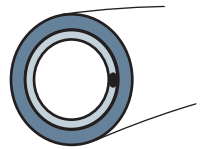

## METAL O-RING EXTERNALLY/INTERNALLY GAS-ENERGISED FACE SEAL

### Features:

- High Load
- Lowest leak rate
- Moderate pressure capability

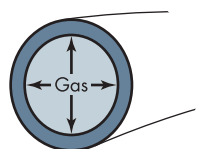

## METAL WIRE-RING EXTERNAL/INTERNAL PRESSURE FACE SEAL

### Features:

- High Load "crush sealing"
- High pressure capability
- Low cost

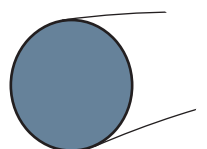

# HOW TO ORDER

## THE PART NUMBER SYSTEM

# CSI-008000-2,39M-I/I-I-S30

The first section of the part number refers to the **TYPE OF SEAL** you want to select:

<b>CI</b>	Metal C-ring, internal pressure face seal
<b>CE</b>	Metal C-ring, external pressure face seal
<b>CSI</b>	Metal C-ring, spring energized, internal pressure face seal
<b>CSE</b>	Metal C-ring, spring energized, external pressure face seal
<b>CA</b>	Metal C-ring, axial seal
<b>CSA</b>	Metal C-ring, spring energized axial seal
<b>OI</b>	Metal O-ring, internal pressure face seal
<b>OE</b>	Metal O-ring, external pressure face seal
<b>OVI</b>	Metal O-ring, internal vented and pressure energized face seal
<b>OVE</b>	Metal O-ring, external vented and pressure energized face seal
<b>OGI</b>	Metal O-ring, pressure filled, internal pressure face seal
<b>OGE</b>	Metal O-ring, pressure filled, external pressure face seal
<b>OSI</b>	Metal O-ring, spring energized, internal pressure face and axial seal
<b>OSE</b>	Metal O-ring, spring energized, external pressure face and axial sea
<b>WI</b>	Metal Wire-ring, internal pressure face seal
<b>WE</b>	Metal Wire-ring, external pressure face seal

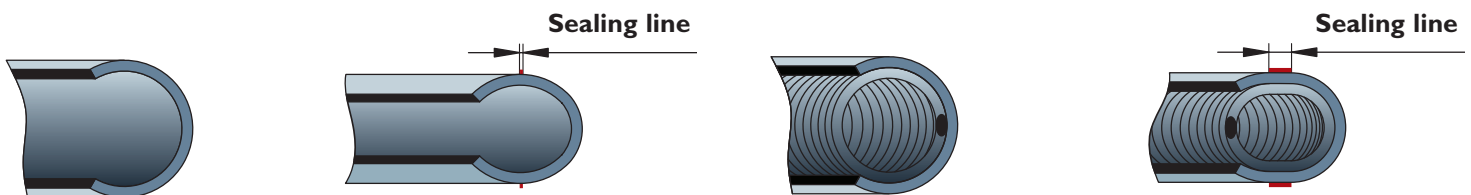

As shown on the figures above, C seals without spring have a smaller sealing surface (after compression) though we need a much higher load to compress the seal. (We can make the same remark for O-seals, with or without spring.)

Depending on the application we propose either spring energized or non spring energized seals.



# CSI-008000-2,39M-I/I-I-S30

This part of the number refers to the **SEAL DIAMETER** (0,01 mm) without plating / coating thickness.

Seal types for internal pressure and all axial seal types: Diameter Seal Outside (DSO).

Seal types for external pressure: Diameter Seal Inside (DSI).

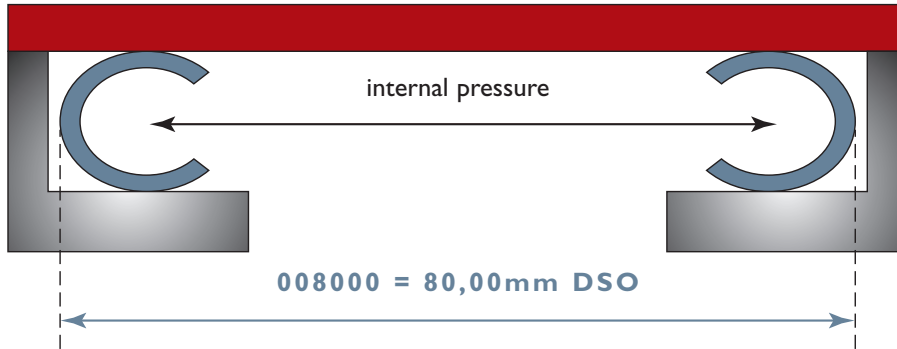

# CSI-008000-2,39M-I/I-I-S30

**2,39** is the **CROSS-SECTION** (free-height) of the seal in mm. The letter **M** refers to the wall thickness of the seal (in this case medium). Seal jackets and springs are available in different standard heights and wall thicknesses:

- L** Light: Lowest available wall thickness. Combines lower load values with higher springback. (Only available for O-Rings)
- M** Medium: Standard wall thickness for spring energized seals, wall thickness for medium duty seals.
- H** Heavy-duty wall thickness, high load values for high-pressure capability.

Please contact Sealco for non-standard dimensions.

For our standard cross-sections and wall-thicknesses we refer to the specific tables further on in this catalogue.

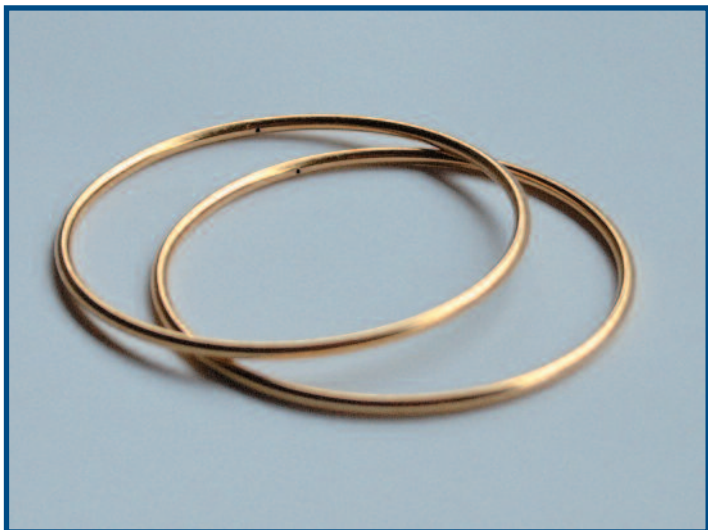

*Metal O-ring, Internal vented, gold plated*



*Metal C-Ring, Axial Seal, non-plated*

# CSI-008000-2,39M-I/I-I-S30

The **MATERIAL CODE** "I/I" indicates the material used for jacket and spring. In this case both seal jacket and spring are made out of Inconel X-750. Code I/9 for example means that the seal jacket consists out of Inconel X-750 (I) and the spring is made out of 302 stainless steel wire (9). The following table will give you a brief overview of the most common standard materials. Our engineering department will carefully select the right seal material for your specific application. Special stainless steels and high performance nickel alloys are our standard materials. Please contact Sealco for non-standard materials.

Code	Material	Code	Material
1	Nickel alloy X-750	6	304 SS , high tensile strength
2	Nickel alloy 718	7	316 SS
3	321 SS	8	Hastelloy
4	Nickel alloy 600	9	302 SS
5	304 SS		

# CSI-008000-2,39M-I/I-I-S30

To obtain other sealing properties (higher load and springback values) our seals can undergo a variety of heat treatments. The different Heat Treatments are indicated by the **TEMPER CODE** in the part number. Beneath you can find a table with the different temper codes we can offer and recommend, depending on the specific application

Temper code	Temper Description	Applicable Material Code
1	Work Hardened	All
2	Age Hardened	Alloy X-750 and 718
3	Annealed	Alloy X-750 and 718
4	Solution and Precipitation heat treatment	Alloy X-750 and 718

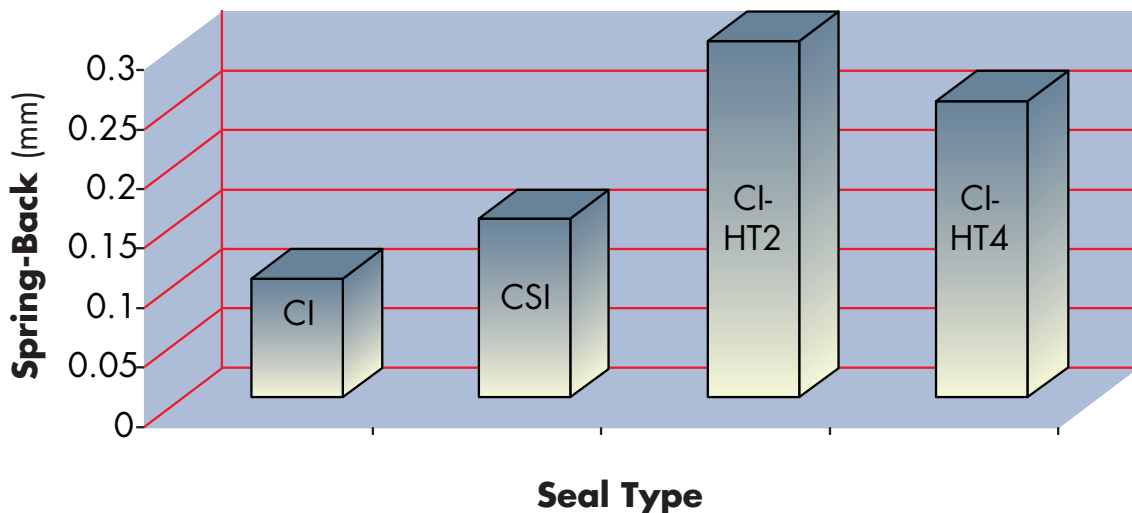

# CSI-008000-2,39M-I/I-I-S30

This last section in our part number determines the **FINISHING LAYER AND THICKNESS**

Sealco can offer a wide range of specialised platings and coatings which creates a ductile outer surface layer and ensures optimum sealing by " filling out " all imperfections in the mating surfaces. The plating or coating layer also reduces the coefficient of friction of the seal so the seal can slide and bed-down during compression what prevents galling.

Seal coatings and platings not only provide better physical properties to the seal (ductility and softness) but are also chosen to withstand high temperatures and aggressive environments (corrosive or oxidising sealing conditions).

The table below can be helpful to determine the type of plating needed. (In most cases silver plating is an added value to improve sealing capacity and to lower leak rate.)

Code	Finish Material	Properties, Uses and limitations
S	Silver (Ag)	Ideal plating, soft (excellent anti-galling, good corrosion and temperature resistance, wide variety of applications, Tmax 430°C (oxydizing), 650°C (non-oxyd+C2izing)
G	Gold (Au)	Soft, excellent chemical and oxidation resistance, Tmax = 930°C
C	Copper (Cu)	Relatively soft, inexpensive, Tmax = 930°C
N	Nickel (Ni)	Hard, used instead of silver in hot, oxydizing environments, Tmax = 1200°C
L	Lead (Pb)	Extremely soft, excellent for cryogenics, use for low load seals (70 N/mm max), Tmax = 200°C
T	Teflon (PTFE)	Extremely soft (no high load seals, 80 N/mm max), chemically inert. Tmax = 230°C
/	Unplated	Applications where no extreme leaktightness is required, Tmax depends on basematerial

The finish of the mating surfaces is an important factor in the choice of the plating/coating thickness. Rougher surfaces require thicker finishes for good sealing capability.

A soft plating like lead can handle larger Ra-values than for instance nickel. The table below is a helpful guideline to choose the finish thickness.

Thickness-code	Finish Thickness	Groove Surface Finish
30	0,01 - 0,03 mm	0,4 Ra max
50	0,03 - 0,05 mm	0,8 Ra max
70	0,05 - 0,07 mm	1,6 Ra max

Thicker finishes are available on request (up to 0,25 mm). Our plating department can handle special tolerances on silver finishes.

Table 1



# OI-DATASHEET

## INTERNAL PRESSURE FACE SEAL; OI / OVI / OGI / OSI

Seal dimensions					Groove Dimensions			
AS			MT	DC	DG	GD	WG	R
Axial Section	Tolerance on AS	Material Code	Material Thickness	Diametrical Clearance	Diameter Groove (range)	Groove Depth (min/max)	Width Groove (minimum)	Radius (maximum)
0,89	+0,08/-0,03	M	0,15	0,2	6,35-25	0,64-0,69	1,4	0,25
1,19	+0,08/-0,03	H	0,20	0,25	10,00-50	0,94-1,02	1,78	0,3
1,57	+0,08/-0,03	L M H	0,15 0,25 0,36	0,28	10-200	1,14-1,27	2,29	0,38
2,39	+0,08/-0,03	L M H	0,15 0,25 0,46	0,33	13-200	1,88-2,01	3,18	0,51
3,18	+0,08/-0,03	M H	0,25 0,51	0,43	25-400	2,54-2,67	4,06	0,76
3,96	+0,10	M H	0,41 0,51	0,61	75-650	3,18-3,30	5,08	1,27
4,78	+0,13	M H	0,51 0,64	0,71	100-800	3,84-3,99	6,35	1,27
6,35	+0,13	M H	0,64 0,81	0,76	200-1200	5,05-5,28	8,89	1,52
9,53	+0,13	M H	0,97 1,24	1,02	300-2000	8,26-8,51	12,7	1,52
12,70	+0,15	M H	1,27 1,65	1,27	800-3000	11,05-11,43	16,51	1,52

Internal pressure seal: Diameter Seal Outside = Reference

FORMULA:  $DSO = DG - DC - (2 \times \text{plating thickness})$

Remarks:

For DG take the Minimum outer groove diameter  
Plating thickness is maximum plating thickness see table I on page 11

Tolerance on seal diameter see table C on page 23  
Tolerance on groove diameter see table A on page 23 column H10

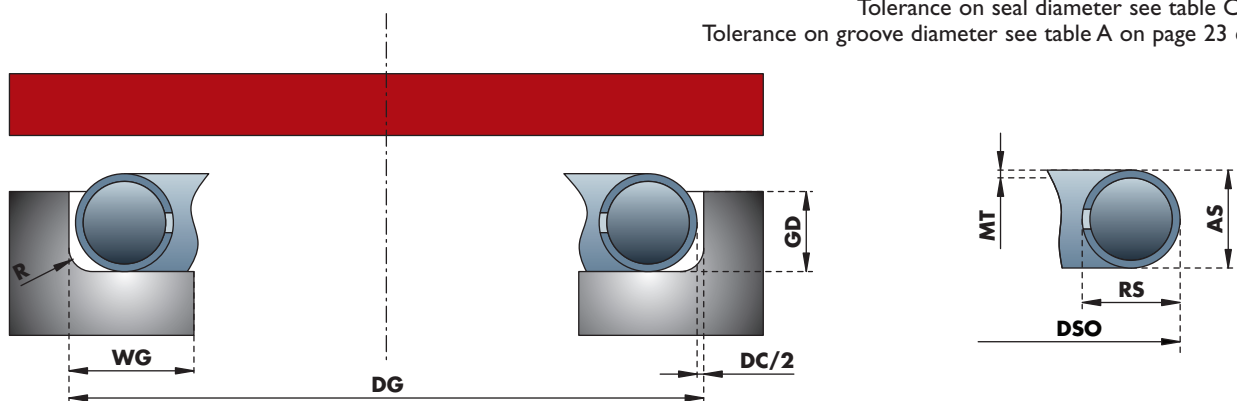

# OE-DATASHEET

## EXTERNAL PRESSURE FACE SEAL; OE / OVE / OGE / OSE

Seal dimensions					Groove Dimensions			
AS			MT	DC	DG	GD	WG	R
Axial Section	Tolerance on AS	Material Code	Material Thickness	Diametrical Clearance	Diameter Groove (range)	Groove Depth (min/max)	Width Groove (minimum)	Radius (maximum)
0,89	+0,08/-0,03	M	0,15	0,2	6,35-25	0,64-0,69	1,4	0,25
1,19	+0,08/-0,03	H	0,20	0,25	10,00-50	0,94-1,02	1,78	0,3
1,57	+0,08/-0,03	L M H	0,15 0,25 0,36	0,28	10-200	1,14-1,27	2,29	0,38
2,39	+0,08/-0,03	L M H	0,15 0,25 0,46	0,33	13-200	1,88-2,01	3,18	0,51
3,18	+0,08/-0,03	M H	0,25 0,51	0,43	25-400	2,54-2,67	4,06	0,76
3,96	+0,10	M H	0,41 0,51	0,61	75-650	3,18-3,30	5,08	1,27
4,78	+0,13	M H	0,51 0,64	0,71	100-800	3,84-3,99	6,35	1,27
6,35	+0,13	M H	0,64 0,81	0,76	200-1200	5,05-5,28	8,89	1,52
9,53	+0,13	M H	0,97 1,24	1,02	300-2000	8,26-8,51	12,7	1,52
12,70	+0,15	M H	1,27 1,65	1,27	800-3000	11,05-11,43	16,51	1,52

External pressure seal: Diameter Seal Inside = Reference

FORMULA:  $DSI = DG + DC + (2 \times \text{plating thickness})$

Remarks:

For DG take the MAXIMUM inner groove diameter  
Plating thickness is maximum plating thickness see table I on page 11

Tolerance on seal diameter see table C on page 23

Tolerance on groove diameter see table A on page 23 column h10

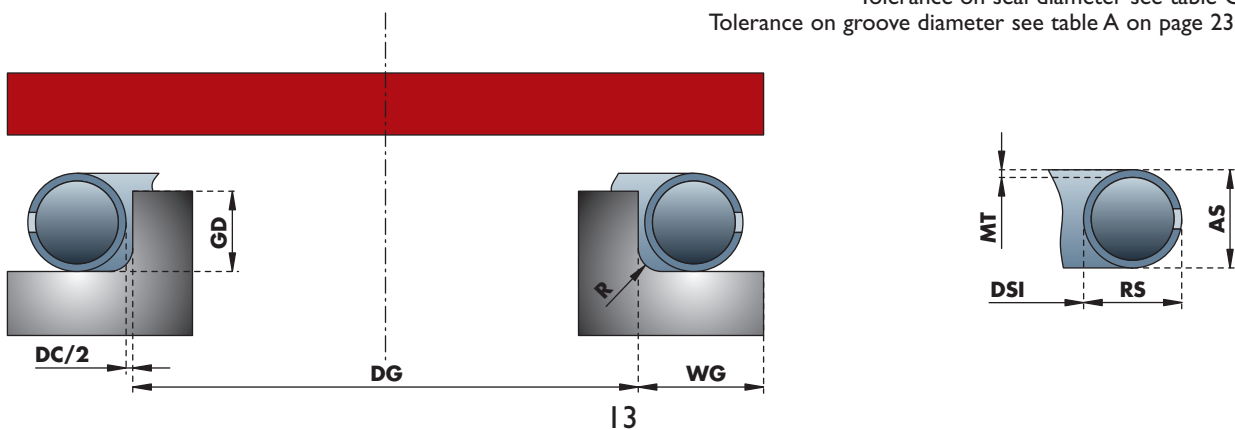

# CI-DATASHEET

## INTERNAL PRESSURE FACE SEAL; CI

Seal dimensions						Groove Dimensions			
AS	RS	MT	DC	DG	GD	WG	R		
Axial Section Tolerance on AS	Radial Section Material Code	Material Thickness	Diametrical Clearance	Diameter Groove (range)	Groove Depth	Width Groove (minimum)	Radius (maximum)		
0,79	+/- 0,05	0,71	M H	0,15 0,18	0,08	6-25	0,64-0,69	1,02	0,25
1,19	+/-0,05	0,96	M H	0,15 0,2	0,15	8-50	0,94-1,02	1,4	0,3
1,57	+/-0,05	1,26	M H	0,15 0,25	0,18	10-200	1,27-1,37	1,91	0,38
2,39	+/-0,05	1,91	M H	0,25 0,38	0,2	13-400	1,91-2,01	2,67	0,51
3,18	+/- 0,08	2,54	M H	0,38 0,51	0,3	25-600	2,54-2,67	3,43	0,76
3,96	+/- 0,08	3,17	M H	0,41 0,61	0,41	32-750	3,18-3,30	4,32	1,27
4,78	+/- 0,10	3,82	M H	0,51 0,76	0,46	75-900	3,84-3,99	5,08	1,27
6,35	+/- 0,10	5,08	M H	0,64 0,97	0,51	100-1200	5,08-5,28	6,6	1,52
9,53	+/- 0,10	7,62	M H	0,97 1,27	0,76	300-2000	7,62-8,03	9,65	1,52
12,70	+/- 0,13	10,16	M H	1,27 1,65	1,02	600-3000	10,16-10,67	12,7	1,52

Internal pressure seal: Diameter Seal Outside = Reference

FORMULA:  $DSO = DG - DC - (2 \times \text{plating thickness})$

Remarks:

For DG take the Minimum outer groove diameter  
 Plating thickness is maximum plating thickness see table I on page 11  
 Tolerance on seal diameter see table B on page 23 column h1 I  
 Tolerance on groove diameter see table A on page 23 column H10

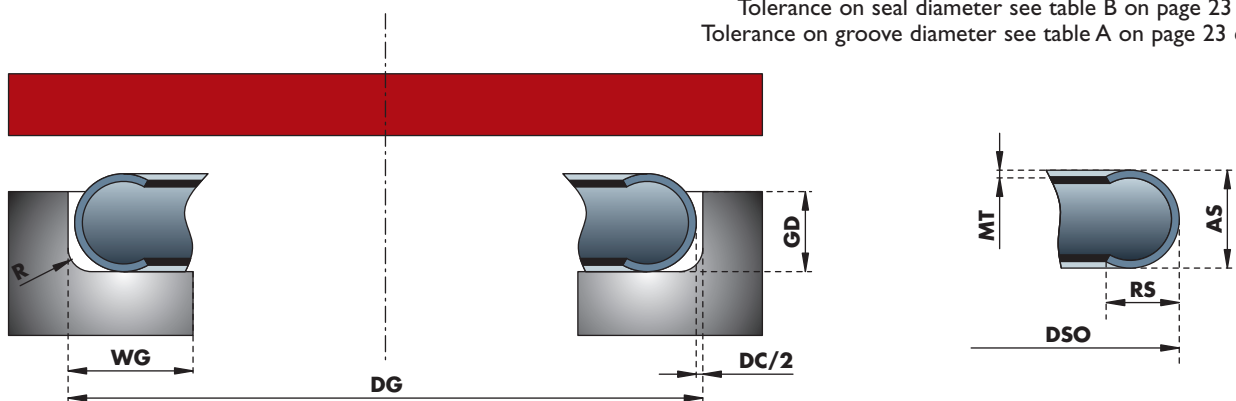



# CE-DATASHEET

## EXTERNAL PRESSURE FACE SEAL; CE

Seal dimensions						Groove Dimensions			
AS	RS	MT	DC	DG	GD	WG	R		
Axial Section	Tolerance on AS	Radial Section	Material Code	Material Thickness	Diametrical Clearance	Diameter Groove (range)	Groove Depth	Width Groove (minimum)	Radius (maximum)
0,79	+/- 0,05	0,71	M H	0,15 0,18	0,08	6-25	0,64-0,69	1,02	0,25
1,19	+/-0,05	0,96	M H	0,15 0,2	0,15	8-50	0,94-1,02	1,4	0,3
1,57	+/-0,05	1,26	M H	0,15 0,25	0,18	10-200	1,27-1,37	1,91	0,38
2,39	+/-0,05	1,91	M H	0,25 0,38	0,2	13-400	1,91-2,01	2,67	0,51
3,18	+/- 0,08	2,54	M H	0,38 0,51	0,3	25-600	2,54-2,67	3,43	0,76
3,96	+/- 0,08	3,17	M H	0,41 0,61	0,41	32-750	3,18-3,30	4,32	1,27
4,78	+/- 0,10	3,82	M H	0,51 0,76	0,46	75-900	3,84-3,99	5,08	1,27
6,35	+/- 0,10	5,08	M H	0,64 0,97	0,51	100-1200	5,08-5,28	6,6	1,52
9,53	+/- 0,10	7,62	M H	0,97 1,27	0,76	300-2000	7,62-8,03	9,65	1,52
12,70	+/- 0,13	10,16	M H	1,27 1,65	1,02	600-3000	10,16-10,67	12,7	1,52

External pressure seal: Diameter Seal Inside = Reference

FORMULA:  $DSI = DG + DC + (2 \times \text{plating thickness})$

Remarks:

For DG take the MAXIMUM inner groove diameter  
Plating thickness is maximum plating thickness see table I on page 11

Tolerance on seal diameter see table B on page 23 column H11  
Tolerance on groove diameter see table A on page 23 column h10

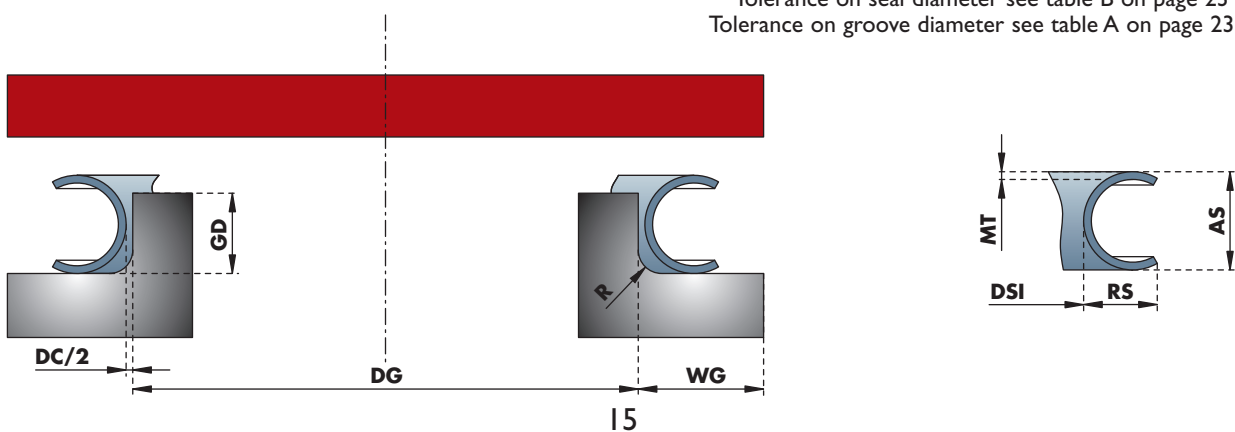

# CSI-DATASHEET

## SPRING ENERGISED, INTERNAL PRESSURE FACE SEAL; CSI

Seal Dimensions						Groove Dimensions			
AS	RS	MT	DC	DG	GD	WG	R		
Axial Section	Tolerance on AS	Radial Section (maximum)	Material Code	Material Thickness	Diametrical Clearance	Diameter Groove (range)	Groove Depth (min/max)	Width Groove (minimum)	Radius (maximum)
1,57	+/- 0,05	1,5	M	0,15	0,15	20-280	1,27-1,37	2,3	0,37
2,39	+/- 0,05	2,21	M	0,25	0,2	25-400	1,91-2,01	3,19	0,51
3,18	+/- 0,08	2,9	M	0,38	0,3	25-600	2,54-2,67	4,07	0,76
3,96	+/- 0,08	3,66	M	0,41	0,41	32-750	3,18-3,30	5,07	1,26
4,78	+/- 0,10	4,39	M	0,51	0,46	75-900	3,84-3,99	6,35	1,26
6,35	+/- 0,10	5,84	M	0,64	0,51	100-1800	5,08-5,28	8,9	1,51
9,53	+/- 0,10	8,69	M	0,97	0,76	300-3000	7,62-8,03	12,7	1,51
12,70	+/- 0,13	11,58	M	1,27	1,02	600-7600	10,16-10,67	16,5	1,51

Internal pressure seal: Diameter Seal Outside = Reference

FORMULA:  $DSO = DG - DC(-2 \times \text{plating thickness})$

Remarks:

For DG take the Minimum outer groove diameter  
Plating thickness is maximum plating thickness see table I on page 11

Tolerance on seal diameter see table B on page 23 column h1 I

Tolerance on groove diameter see table A on page 23 column H10

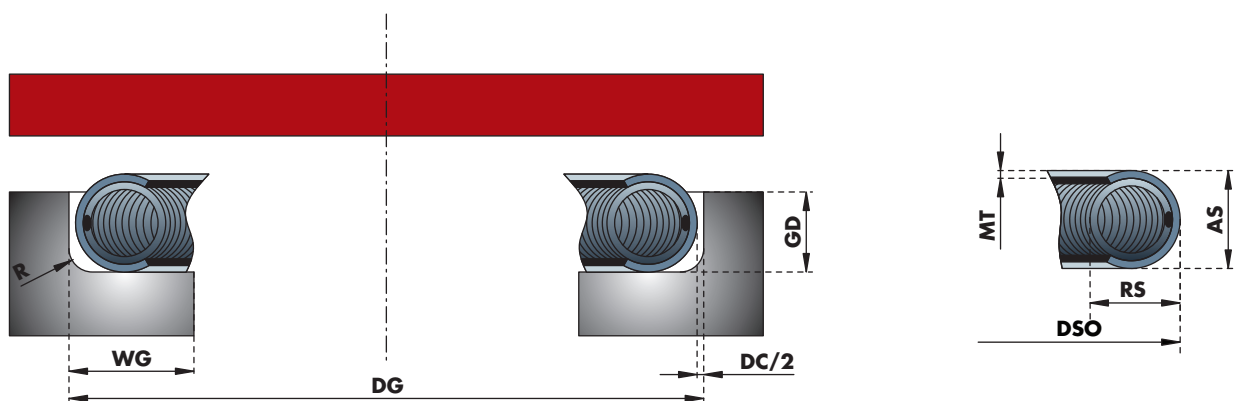

# CSE - DATASHEET

## SPRING ENERGISED, EXTERNAL PRESSURE FACE SEAL; CSE

Seal Dimensions						Groove Dimensions			
AS		RS	MT	DC		DG	GD	WG	R
Axial Section	Tolerance on AS	Radial Section (maximum)	Material Code	Material Thickness	Diametrical Clearance	Diameter Groove (range)	Groove Depth (min/max)	Width Groove (minimum)	Radius (maximum)
1,57	+/- 0,05	1,5	M	0,15	0,15	20-280	1,27-1,37	2,3	0,37
2,39	+/- 0,05	2,21	M	0,25	0,2	25-400	1,91-2,01	3,19	0,51
3,18	+/- 0,08	2,9	M	0,38	0,3	25-600	2,54-2,67	4,07	0,76
3,96	+/- 0,08	3,66	M	0,41	0,41	32-750	3,18-3,30	5,07	1,26
4,78	+/- 0,10	4,39	M	0,51	0,46	75-900	3,84-3,99	6,35	1,26
6,35	+/- 0,10	5,84	M	0,64	0,51	100-1800	5,08-5,28	8,9	1,51
9,53	+/- 0,10	8,69	M	0,97	0,76	300-3000	7,62-8,03	12,7	1,51
12,70	+/- 0,13	11,58	M	1,27	1,02	600-7600	10,16-10,67	16,5	1,51

External pressure seal: Diameter Seal Inside = Reference

FORMULA:  $DSI = DG + DC + (2 \times \text{plating thickness})$

Remarks:

For DG take the MAXIMUM inner groove diameter  
 Plating thickness is maximum plating thickness see table I on page 11  
 Tolerance on seal diameter see table B on page 23 column H11  
 Tolerance on groove diameter see table A on page 23 column h10

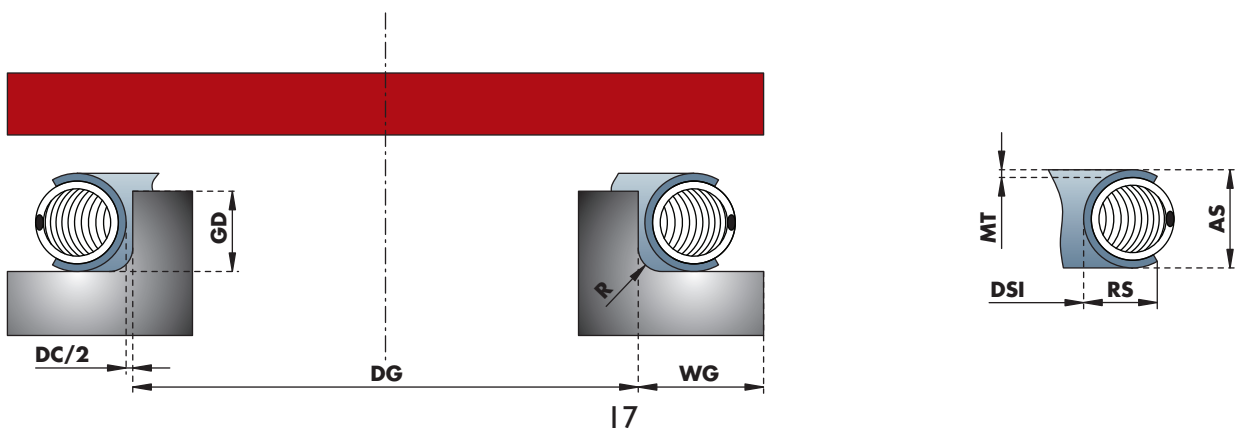



# CA-DATASHEET

## AXIAL SEAL; CA

Seal dimensions					
RS		MT	DSO	DSI	
Radial Section	Material code	Material Thickness	Diameter Seal Outside	Diameter Seal Inside	Tolerance on DSO and DSI
1,57	M	0,15	BD +0,08	DSO -3,28	+/- 0,03
1,57	M	0,15	BD +0,10	DSO -3,28	+/- 0,03
2,39	M	0,25	BD +0,08	DSO -4,85	+/- 0,03
2,39	M	0,25	BD +0,10	DSO -4,85	+/- 0,03
3,18	M	0,38	BD +0,10	DSO -6,45	+/- 0,03
3,18	M	0,38	BD +0,15	DSO -6,45	+/- 0,05
3,18	M	0,38	BD +0,20	DSO -6,45	+/- 0,05
3,96	M	0,41	BD +0,15	DSO -8,03	+/- 0,05
3,96	M	0,41	BD +0,20	DSO -8,03	+/- 0,05
4,78	M	0,51	BD +0,15	DSO -9,63	+/- 0,05
4,78	M	0,51	BD +0,20	DSO -9,63	+/- 0,05
6,35	M	0,64	BD +0,20	DSO -12,80	+/- 0,05

**Axial pressure seal: Diameter Seal Outside = Reference**

**FORMULA: DSO = DSO (see table above)**

**Remarks:**

For seal calculation always take BD Minimum

### CAVITY REQUIREMENTS:

Bore diameter less 85 mm requires 0,015 maximum concentricity, above 85 mm 0,03.

Static mating surface 0,2 - 0,4 Ra, dynamic 0,1 - 0,2 Ra.

Hardness should be 60 Rc in both conditions.

The pressure-rating for CA seals is 59MPa (1,57M, 2,39M, 3,96M and 6,35M) up to 85 MPa for the 3,18M

# CA-DATASHEET

## AXIAL SEAL; CA

### Groove Dimensions

BD		SD		WG	R
Bore Diameter (range)	Tolerance on BD	Shaft/Rod Diameter	Tolerance on RS	Width Groove (minimum)	Radius (maximum)
12,70-38,00	+0,03	BD -3,12	-0,03	1,3	0,38
38,01-45,00	+0,03	BD -3,07	-0,03	1,3	0,38
30,00-38,00	+0,03	BD -4,70	-0,03	1,98	0,51
38,01-85,00	+0,03	BD -4,65	-0,03	1,98	0,51
50,00-85,00	+0,03	BD -6,25	-0,03	2,64	0,76
85,01-150,00	+0,05	BD -6,15	-0,05	2,64	0,76
150,01-200,00	+0,05	BD -6,05	-0,05	2,64	0,76
85,00-150,00	+0,05	BD -7,72	-0,05	3,28	1,27
150,01-250,00	+0,05	BD -7,62	-0,05	3,28	1,27
100,00-150,00	+0,05	BD -9,32	-0,05	3,96	1,27
150,01-300,00	+0,05	BD -9,22	-0,05	3,96	1,27
150,00-300,00	+0,05	BD -12,40	-0,05	5,28	1,52

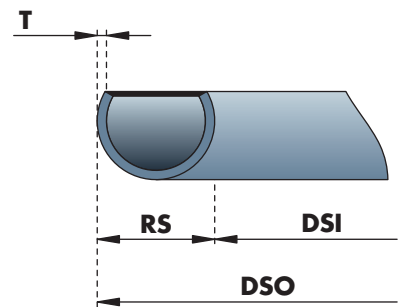
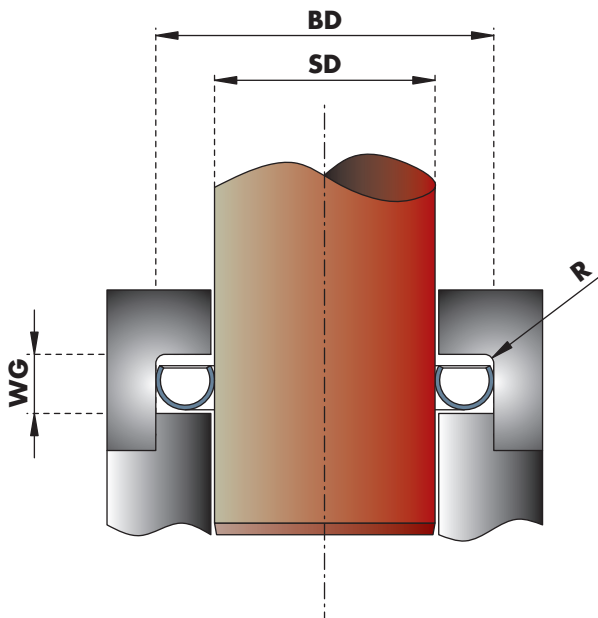

# WI-DATASHEET

## INTERNAL PRESSURE FACE SEAL; WI

Seal dimensions			Groove Dimensions			
AS		DC	DG	GD	WG	R
Axial Section	Tolerance on AS	Diametrical Clearance	Diameter Groove (range)	Groove Depth (min/max)	Width Groove (minimum)	Radius (maximum)
0,89	+0,08/-0,03	0,2	6,00-25	0,64-0,69	1,4	0,25
1,57	+0,08/-0,03	0,28	10-200	0,94-1,02	2,29	0,38
2,39	+0,08/-0,03	0,33	20-400	1,88-2,01	3,18	0,51
3,18	+0,08/-0,03	0,43	32-600	2,54-2,67	4,06	0,76

Internal pressure seal: Diameter Seal Outside = Reference

FORMULA:  $DSO = DG - DC - (2 \times \text{plating thickness})$

Remarks:

For DG take the Minimum outer groove diameter  
 Plating thickness is maximum plating thickness see table I on page 11  
 Tolerance on seal diameter see table C on page 23  
 Tolerance on groove diameter see table A on page 23 column H10

Wire rings are used as reinforcement rings for compensators (bellows), air channels etc.  
 Wire rings are made out of stainless steel with cross section diameters that ranges from 2 to 12 mm.  
 Since there are no standards we always make these rings tailor made according to our client demands (stainless steel type, diameter, cross section, tolerances, ...)

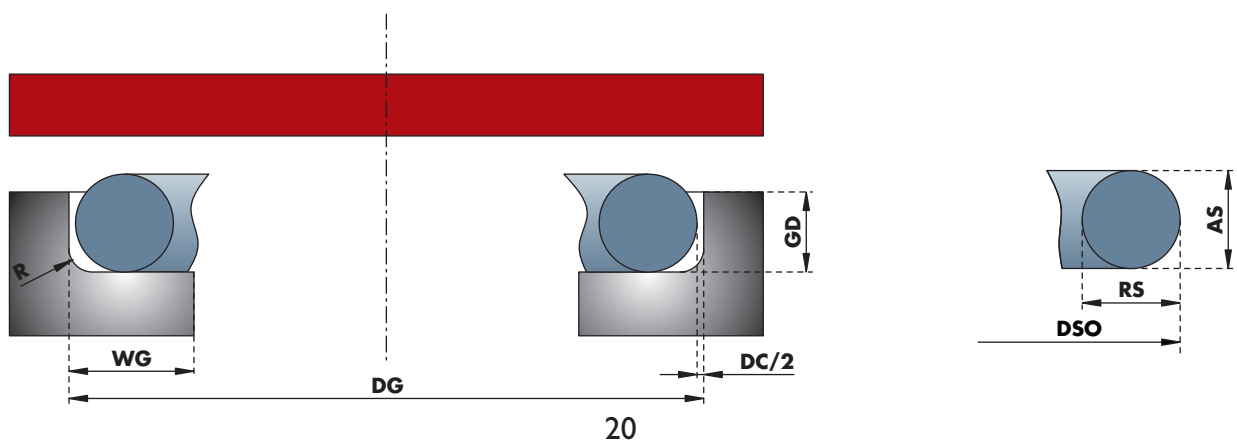



# WE-DATASHEET

## EXTERNAL PRESSURE FACE SEAL; WE

Seal dimensions			Groove Dimensions			
AS		DC	DG	GD	WG	R
Axial Section	Tolerance on AS	Diametrical Clearance	Diameter Groove (range)	Groove Depth (min/max)	Width Groove (minimum)	Radius (maximum)
0,89	+0,08/-0,03	0,2	6,00-25	0,64-0,69	1,4	0,25
1,57	+0,08/-0,03	0,28	10-200	0,94-1,02	2,29	0,38
2,39	+0,08/-0,03	0,33	20-400	1,88-2,01	3,18	0,51
3,18	+0,08/-0,03	0,43	32-600	2,54-2,67	4,06	0,76

External pressure seal: Diameter Seal Inside = Reference

FORMULA:  $DSI = DG + DC + (2 \times \text{plating thickness})$

Remarks:

For DG take the MAXIMUM inner groove diameter  
Plating thickness is maximum plating thickness see table I on page 11

Tolerance on seal diameter see table C on page 23

Tolerance on groove diameter see table A on page 23 column h10

Wire rings are used as reinforcement rings for compensators (bellows), air channels etc.

Wire rings are made out of stainless steel with cross section diameters that ranges from 2 to 12 mm.

Since there are no standards we always make these rings tailor made according to our client demands (stainless steel type, diameter, cross section, tolerances, ...)

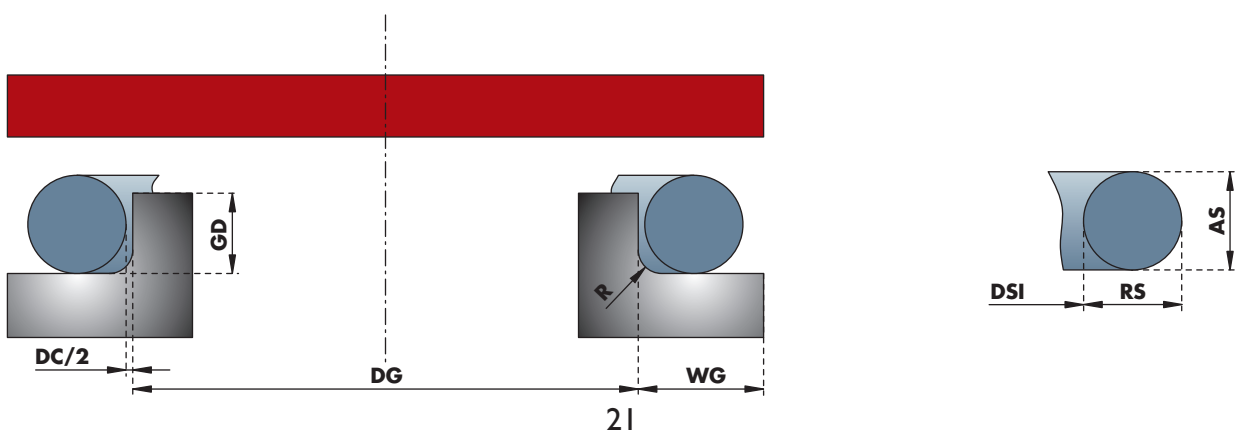

# SHAPED SEALS

## SHAPED SEALS; ANY SHAPE, ANY SIZE

Sealco offers shaped seals, custom made in all possible shapes.

For various applications, the availability of special shaped metal seals offers great design flexibility.

O seals are the most flexible to shape, they can be formed in almost any shape.

C seals can also be shaped, but there are limitations in the shape type.

For each cross section there is a limitation in the applied radius.

The table below indicates the minimum outer corner radius for various cross sections of metal O , C and W rings.

<b>Axial Section</b>	0,79	0,89	1.19	1.57	2.39	3.18	3.96	4.78	6.35	9.53	12.7	15.88
<b>Minimum Outer Radius</b>	3.2	3.2	5	6.5	13	25	50	75	100	200	300	400

# SPECIALS

## OTHER HIGH TECH METAL SEALS, SPECIAL DESIGNS

Sealco can offer besides O and C-types of metal seal a variety of other seal types: U-rings, V-rings, seals with internal limiters, etc.

We know there are many applications that demand special designed seals. Sealco will be pleased to help you finding the right solution for your specific application.

Sealco is an innovative company; our specialists and partner engineers at HTMS are determined to find the ideal sealing solution for you.

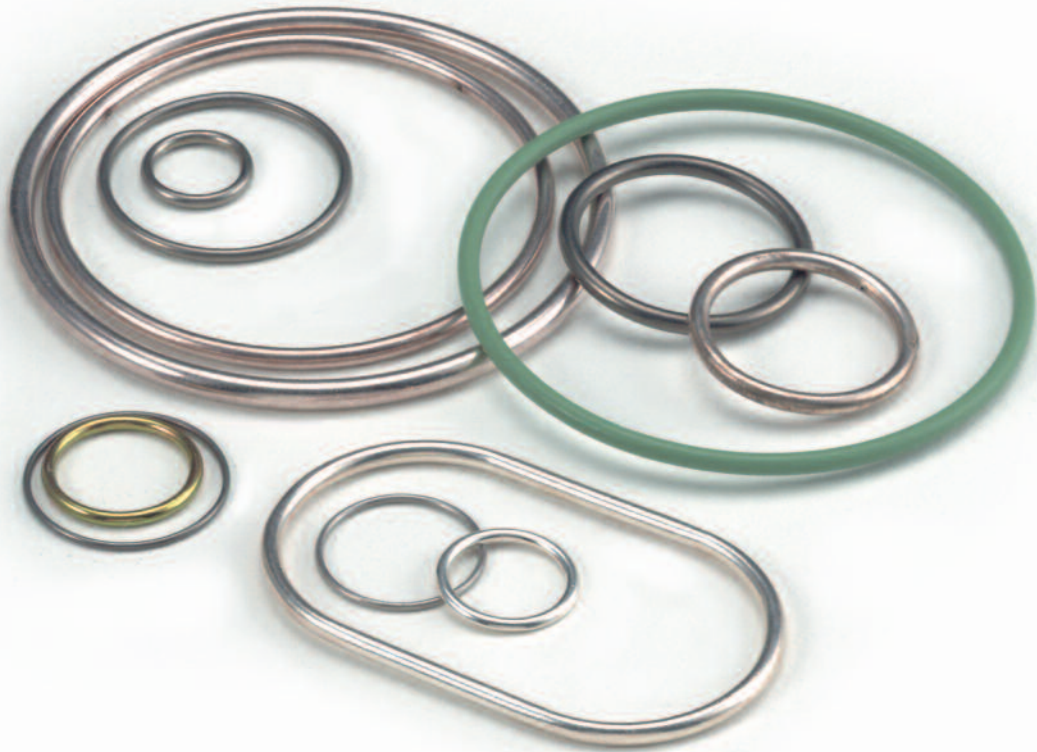

*Seals in any shape and size*

TABLE A

## TOLERANCES

TABLE B

Groove Tolerances		
Nominal Diameter mm	Tolerances in $\mu\text{m}$	
	h10	H10
0-3	0 / -40	0 / +40
3-6	0 / -48	0 / +48
6-10	0 / -58	0 / +58
10-18	0 / -70	0 / +70
18-30	0 / -84	0 / +84
30-50	0 / -100	0 / +100
50-80	0 / -120	0 / +120
80-120	0 / -140	0 / +140
120-180	0 / -160	0 / +160
180-250	0 / -185	0 / +185
250-315	0 / -210	0 / +210
315-400	0 / -230	0 / +230
400-500	0 / -250	0 / +250
500-760	0 / -300	0 / +300
760-1050	0 / -400	0 / +400
1050-1425	0 / -500	0 / +500
1425-1940	0 / -630	0 / +630

C-Ring Tolerances		
Nominal Diameter mm	Tolerances in $\mu\text{m}$	
	h11	H11
0-3	0 / -60	0 / +60
3-6	0 / -75	0 / +75
6-10	0 / -90	0 / +90
10-18	0 / -110	0 / +110
18-30	0 / -130	0 / +130
30-50	0 / -160	0 / +160
50-80	0 / -190	0 / +190
80-120	0 / -220	0 / +220
120-180	0 / -250	0 / +250
180-250	0 / -290	0 / +290
250-315	0 / -320	0 / +320
315-400	0 / -360	0 / +360
400-500	0 / -400	0 / +400
500-760	0 / -500	0 / +500
760-1050	0 / -630	0 / +630
1050-1425	0 / -760	0 / +760
1425-1940	0 / -1000	0 / +1000

O-Ring Tolerances on O-Ring Diameter	
Cross Section(mm)	Tolerances in $\mu\text{m}$
0,89-4,78	+ 130
4,79-9,52	+200
9,53-12,70	+250

TABLE C

# CONVERSIONS

pascale conversion	
To convert to pascale	Multiply by
atmosphere	$1,013 \times 10^5$
bar	$1,000 \times 10^5$
dyne/centimeter <sup>2</sup>	$1,000 \times 10^1$
inch of mercury (0°C)	$3,386 \times 10^3$
inch of water (4°C)	$2,491 \times 10^2$
kilogram/meter <sup>2</sup>	9.807
pound/inch <sup>2</sup> (psi)	$6,894 \times 10^3$
pound/foot <sup>2</sup>	$4,788 \times 10^1$
torr (mm of mercury 0°C)	$1,333 \times 10^2$

psi conversion	
To PSI	From PSI
psi = in. of H <sub>2</sub> O x $(3,6127 \times 10^{-2})$	in. of H <sub>2</sub> O = psi x 27,68
psi = in. of Hg x (0,49118)	in. of Hg = psi x 2,036
psi = mm of H <sub>2</sub> O x $(1,4223 \times 10^{-3})$	mm of H <sub>2</sub> O = psi x 703,1
psi = mm of Hg x $(1,9339 \times 10^{-2})$	mm of Hg = psi x 51,71
psi = cm of H <sub>2</sub> O x $(14,223 \times 10^{-3})$	cm of H <sub>2</sub> O = psi x 70,3
psi = kg/cm <sup>2</sup> x (14,223)	kg/cm <sup>2</sup> = psi x 0,0703
psi = bar x (14,503)	bar = psi x 0,0689
psi = mbar x $(1,4503 \times 10^{-2})$	mbar = psi x 68,95
psi = Pa x $(1,4503 \times 10^{-4})$	Pa = psi x 6895
psi = kPa x $(1,4503 \times 10^{-1})$	kPa = psi x 6,895

metric	
English	Metric
1 mm = 0,03937 in.	in. = 25,4mm
1 cm = 0,3937 in.	in. = 2,54cm
1 m = 39,37 in.	in. = $2,54 \times 10^{-2}$

Temperature	
Celcius	Fahrenheit
°C = $(°F-32)/1,8$	°F = $1,8°C + 32$



# OTHER SEALCO PRODUCTS

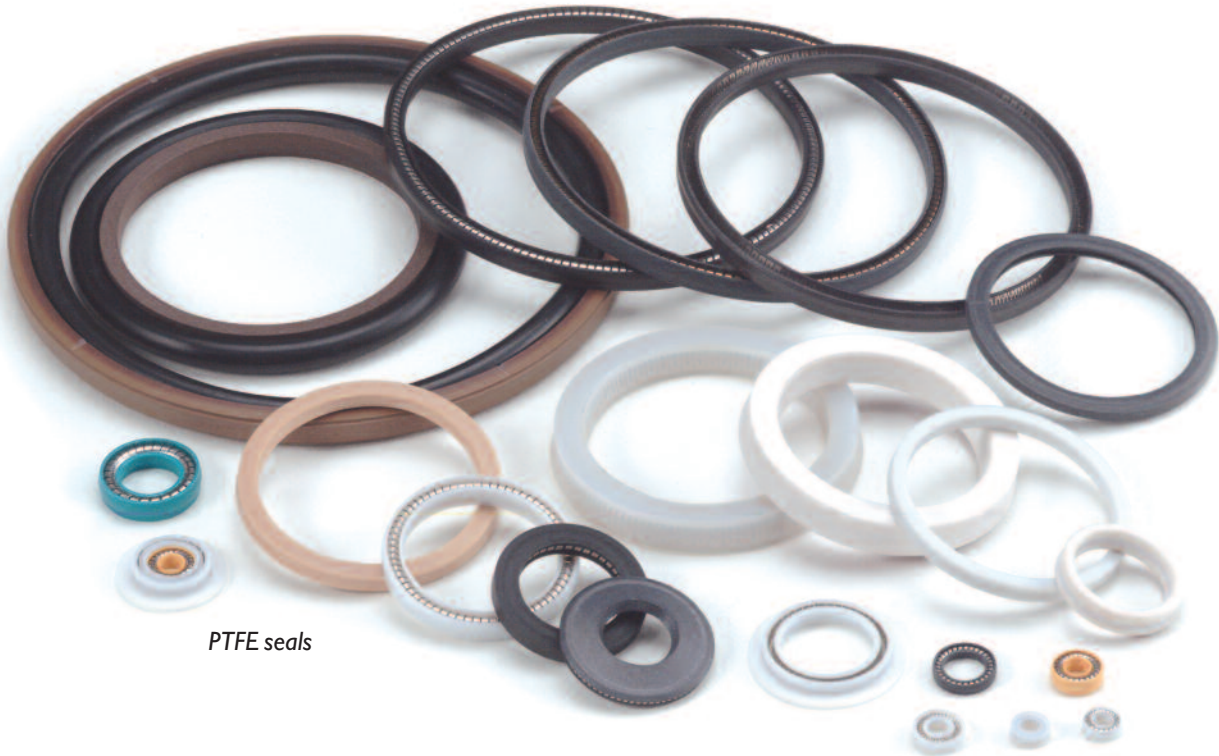

*PTFE seals*

## PTFE / PTFE SPRING ENERGISED

We offer a comprehensive range of PTFE spring energised and Hydraulic Seals, which includes, Piston, Rod, Scraper, Rotary either O Ring energised or Spring Energised. Our Springs can be produced to NACE approval.

## PTFE ROTARY SHAFT SEALS

PTFE lip seals bridge the gap between current technologies for both gas and liquid sealing applications. In many applications PTFE Rotary Shaft Seals can remove the need to change to bulky, multi-component mechanical face seals. Our PTFE Rotary Shaft Seals offer impressive operating characteristics. They can run at speeds of 30 metres/sec, and cope with pressures up to 35 bar and temperatures  $-20^{\circ}\text{C}$  to  $+250^{\circ}\text{C}$ . They are resistant to chemical attack, have low friction characteristics and are designed to ensure long seal life even in conditions of no lubrication or when used with abrasive media.



*PTFE rotary seals*

## O RINGS AND CORD

O rings & back-up

British Standard Imperial (BS) and British Metric (RM) sizes as well as Swedish, German, French and Japanese (JIS) metric sizes in Nitrile, Viton, Silicone, Fluorosilicone, Ethylene Propylene (E.P.D.M.), Neoprene, NWC (National Water Council approved), FEP (Viton and Silicone encapsulated), High Nitrile and Food Grade materials in a variety of shore hardness's, as well as in P.T.F.E. to suit both static and dynamic applications.



## BACK-UP RINGS

Spiral, Single Cut and Solid P.T.F.E. as well as Rubber and Polyurethane Contoured back-up rings.

## ROTARY SHAFT SEALS

In a variety of materials and styles ranging from standard metal cased and rubber covered; single and double lipped types to split seals (up to 1000mm diameter) and unitised seals for Truck and Trailer axles. Sealco offer the added benefit of producing metal cased shaft seals to customer's specifications.



Rotary seals

## SHAFT REPAIR KITS

The lower cost alternative to replacing or reworking of damaged shafts, thereby reducing machine downtime.

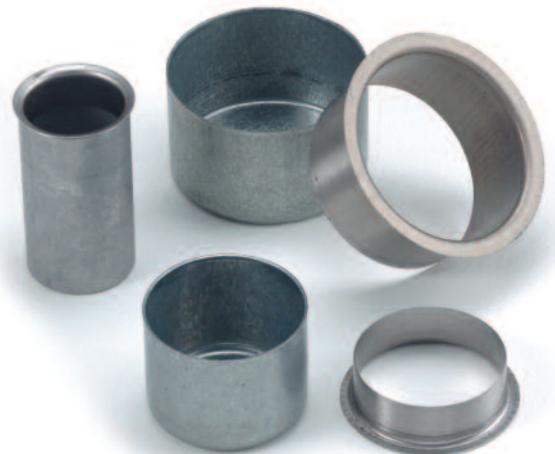

Shaft repair kits



## FRONT SEALS

A Flexible all rubber, low cost seal available in a variety of profiles, which stretch fit onto the shaft, sealing axially against a counterface, up to 2000mm shaft diameter available. In either Nitrile or Viton



*Front seals*

## GLAND / PISTON SEALS

Gland and Piston seals are available in a wide range of styles and materials for both single and double acting applications to suit all types of Hydraulic and Pneumatic equipment.

*Gland / Piston seals*



## WIPER / SCRAPER SEALS

Styles to suit Light, Medium and Heavy Duty environments in a variety of profiles. Manufactured in flexible rubber, polyurethane, Nylon and metal re-enforced (for press fit applications).



*Wipers / Scrapers*





# SEALCO

PERFORMANCE SEALING SOLUTIONS

SEALCO HOUSE

Maypole Fields, Halesowen, West Midlands B63 2QB

---

t: 01384 413058 f: 01384 568729

e: [sales@sealco.co.uk](mailto:sales@sealco.co.uk)

w: [www.sealco.co.uk](http://www.sealco.co.uk)

---